

e-zsert  [®]

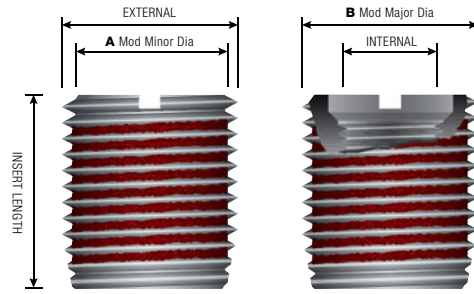

TECHNICAL DATA

INSERT STYLE
THIN WALL



UNC / UNF SERIES

PART #	INTERNAL THREAD INCH 2B	EXTERNAL THREAD INCH 2B	MATERIAL	L INCH	A MOD MINOR DIA. INCH	B MAJOR DIA. INCH
3332-10GTW	10-24	5/16-18	C12L14 Carbon Steel	0.312	.251 - .254	.307 - .311
3334-10GTW	10-32	5/16-18	C12L14 Carbon Steel	0.312	.251 - .254	.307 - .311
3332-1/4TW	1/4-20	3/8-16	C12L14 Carbon Steel	0.375	.314 - .318	.369 - .373
3334-1/4TW	1/4-28	3/8-16	C12L14 Carbon Steel	0.375	.314 - .318	.369 - .373
3332-5/16TW	5/16-18	7/16-14	C12L14 Carbon Steel	0.437	.377 - .381	.432 - .436
3334-5/16TW	5/16-24	7/16-14	C12L14 Carbon Steel	0.437	.377 - .381	.432 - .436
3332-3/8TW	3/8-16	1/2-13	C12L14 Carbon Steel	0.500	.434 - .438	.494 - .498
3334-3/8TW	3/8-24	1/2-13	C12L14 Carbon Steel	0.500	.434 - .438	.494 - .498
3332-7/16TW	7/16-14	9/16-12	C12L14 Carbon Steel	0.560	.497 - .501	.556 - .560
3334-7/16TW	7/16-20	9/16-12	C12L14 Carbon Steel	0.560	.497 - .501	.556 - .560
3332-1/2TW	1/2-13	5/8-11	C12L14 Carbon Steel	0.620	.553 - .557	.619 - .623
3334-1/2TW	1/2-20	5/8-11	C12L14 Carbon Steel	0.620	.553 - .557	.619 - .623

METRIC INTERNAL UNC EXTERNAL SERIES

PART #	INTERNAL THREAD MM 6H	EXTERNAL THREAD INCH 2B	MATERIAL	L INCH	A MOD MINOR DIA. INCH	B MAJOR DIA. INCH
3320-4.00TWF	M4-0.7	5/16-18	C12L14 Carbon Steel	0.312	.251 - .254	.307 - .311
3320-5.00TWF	M5-0.8	5/16-18	C12L14 Carbon Steel	0.312	.251 - .254	.307 - .311
3320-6.00TWF	M6-1.0	3/8-16	C12L14 Carbon Steel	0.375	.314 - .318	.369 - .373
3320-8.00TWF	M8-1.25	7/16-14	C12L14 Carbon Steel	0.437	.377 - .381	.432 - .436
3320-10.00TWF	M10-1.5	1/2-13	C12L14 Carbon Steel	0.500	.434 - .438	.494 - .498
3320-12.00TWF	M12-1.75	5/8-11	C12L14 Carbon Steel	0.625	.553 - .557	.619 - .623

INSERT STYLE
THIN WALL

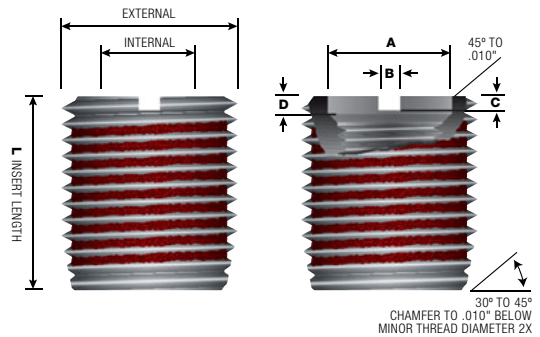

METRIC SERIES

PART #	INTERNAL THREAD MM 6H	EXTERNAL THREAD MM 6G	MATERIAL	L MM	A MM	B MM	C MM	D MM
3320-3.00TWM	M3-0.5	M6-1.0	C12L14 Carbon Steel	6.5	3.25	1.14	1.57	1.91
3320-4.00TWM	M4-0.7	M8-1.25	C12L14 Carbon Steel	7.5	4.32	1.65	1.65	1.91
3320-5.00TWM	M5-0.8	M8-1.25	C12L14 Carbon Steel	7.5	5.33	1.65	1.65	1.91
3320-6.00TWM	M6-1.0	M10-1.5	C12L14 Carbon Steel	10.5	6.35	1.83	1.83	2.03
3320-8.00TWM	M8-1.25	M12-1.75	C12L14 Carbon Steel	12.5	8.33	1.83	1.83	2.03
3320-10.00TWM	M10-1.5	M16-2.0	C12L14 Carbon Steel	17.0	10.31	2.62	2.16	2.41
3320-12.00TWM	M12-1.75	M16-2.0	C12L14 Carbon Steel	17.0	12.32	3.35	2.79	2.92
3320-16.00TWM	M16-2.0	M24-3.0	C12L14 Carbon Steel	20.0	16.66	3.35	3.18	3.30
3320-20.00TWM	M20-2.5	M36-4.0	C12L14 Carbon Steel	30.0	20.50	3.35	3.35	3.56

INSERT STYLE

THIN WALL

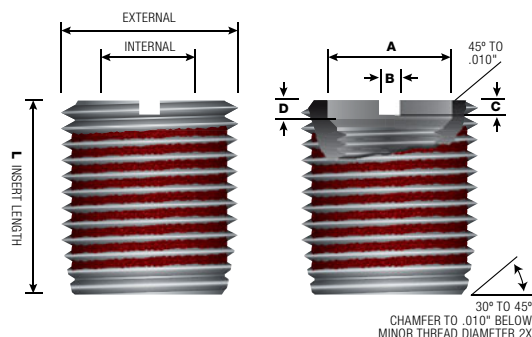

METRIC SERIES

PART #	INTERNAL THREAD MM 6H	EXTERNAL THREAD MM 6G	MATERIAL	L MM	A MM	B MM	C MM	D MM
3320-3.00HWMSS	M3-0.5	M6-1.0	303 Stainless Steel	6.5	3.25	1.14	1.57	1.91
3320-4.00HWMSS	M4-0.7	M8-1.25	303 Stainless Steel	7.5	4.32	1.65	1.65	1.91
3320-5.00HWMSS	M5-0.8	M8-1.25	303 Stainless Steel	7.5	5.33	1.65	1.65	1.91
3320-6.00HWMSS	M6-1.0	M10-1.5	303 Stainless Steel	10.5	6.35	1.83	1.83	2.03
3320-8.00HWMSS	M8-1.25	M12-1.75	303 Stainless Steel	12.5	8.33	1.83	1.83	2.03
3320-10.00HWMSS	M10-1.5	M16-2.0	303 Stainless Steel	17.0	10.31	2.62	2.16	2.41
3320-12.00HWMSS	M12-1.75	M16-2.0	303 Stainless Steel	17.0	12.32	3.35	2.79	2.92
3320-16.00HWMSS	M16-2.0	M24-3.0	303 Stainless Steel	20.0	16.66	3.35	3.18	3.30

INSERT STYLE

HEAVY WALL



UNC / UNF SERIES

PART #	INTERNAL THREAD INCH 2B	EXTERNAL THREAD INCH 2B	MATERIAL	L INCH	A INCH	B INCH	C INCH	D INCH
3332-4GHW	4-40	10-32	C12L14 Carbon Steel	0.250	0.122	0.064	0.062	0.065
3332-6GHW	6-32	1/4-20	C12L14 Carbon Steel	0.280	0.148	0.064	0.062	0.070
3332-8GHW	8-32	5/16-18	C12L14 Carbon Steel	0.290	0.177	0.064	0.062	0.075
3332-10GHW	10-24	3/8-16	C12L14 Carbon Steel	0.406	0.201	0.064	0.070	0.080
3334-10GHW	10-32	3/8-16	C12L14 Carbon Steel	0.406	0.201	0.064	0.070	0.080
3332-1/4HW	1/4-20	7/16-14	C12L14 Carbon Steel	0.437	0.261	0.072	0.075	0.085
3334-1/4HW	1/4-28	7/16-14	C12L14 Carbon Steel	0.437	0.261	0.072	0.075	0.085
3332-5/16HW	5/16-18	1/2-13	C12L14 Carbon Steel	0.484	0.323	0.081	0.080	0.090
3334-5/16HW	5/16-24	1/2-13	C12L14 Carbon Steel	0.484	0.323	0.081	0.080	0.090
3332-3/8HW	3/8-16	9/16-12	C12L14 Carbon Steel	0.515	0.386	0.091	0.085	0.095
3334-3/8HW	3/8-24	9/16-12	C12L14 Carbon Steel	0.515	0.386	0.091	0.085	0.095
3332-7/16HW	7/16-14	5/8-11	C12L14 Carbon Steel	0.656	0.447	0.130	0.110	0.115
3334-7/16HW	7/16-24	5/8-11	C12L14 Carbon Steel	0.656	0.447	0.130	0.110	0.115
3332-1/2HW	1/2-13	3/4-10	C12L14 Carbon Steel	0.656	0.510	0.130	0.110	0.115
3332-1/2X1HW	1/2-13	3/4-10	C12L14 Carbon Steel	1.000	0.510	0.130	0.110	0.115
3334-1/2HW	1/2-20	3/4-10	C12L14 Carbon Steel	0.656	0.510	0.130	0.110	0.115
3332-9/16HW	9/16-12	3/4-10	C12L14 Carbon Steel	0.656	0.578	0.130	0.110	0.115
3334-9/16HW	9/16-18	3/4-10	C12L14 Carbon Steel	0.656	0.578	0.130	0.110	0.115
3332-5/8HW	5/8-11	7/8-9	C12L14 Carbon Steel	0.687	0.640	0.130	0.125	0.130
3332-5/8X1.125HW	5/8-11	7/8-9	C12L14 Carbon Steel	1.125	0.640	0.130	0.125	0.130
3334-5/8HW	5/8-18	7/8-9	C12L14 Carbon Steel	0.687	0.640	0.130	0.125	0.130
3332-3/4HW	3/4-10	1-8	C12L14 Carbon Steel	0.781	0.765	0.130	0.125	0.130
3334-3/4HW	3/4-16	1-8	C12L14 Carbon Steel	0.781	0.765	0.130	0.125	0.130
3332-7/8HW	7/8-9	1.1/4-7	C12L14 Carbon Steel	1.125	0.890	0.130	0.135	0.130
3334-7/8HW	7/8-14	1.1/4-7	C12L14 Carbon Steel	1.125	0.890	0.130	0.135	0.130
3332-1HW	1-8	1.3/8-12	C12L14 Carbon Steel	1.250	1.020	0.130	0.135	0.140
3334-1HW	1-14	1.3/8-12	C12L14 Carbon Steel	1.250	1.020	0.130	0.135	0.140

INSERT STYLE
HEAVY WALL

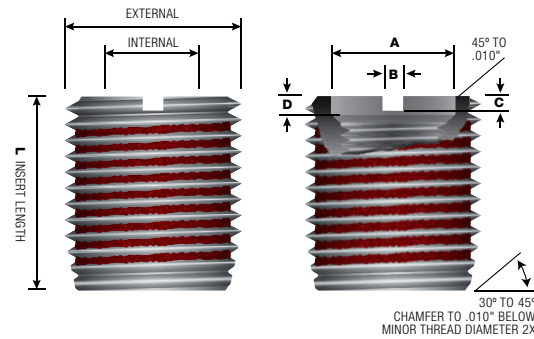

UNC / UNF SERIES								
PART #	INTERNAL THREAD INCH 2B	EXTERNAL THREAD INCH 2B	MATERIAL	L INCH	A INCH	B INCH	C INCH	D INCH
3332-4GHWSS	4-40	10-32	303 Stainless Steel	0.250	0.122	0.064	0.602	0.065
3332-6GHWSS	6-32	1/4-20	303 Stainless Steel	0.280	0.148	0.064	0.062	0.070
3332-8GHWSS	8-32	5/16-18	303 Stainless Steel	0.290	0.177	0.064	0.062	0.075
3332-10GHWSS	10-24	3/8-16	303 Stainless Steel	0.406	0.201	0.064	0.070	0.080
3334-10GHWSS	10-32	3/8-16	303 Stainless Steel	0.406	0.201	0.064	0.070	0.080
3332-1/4HWSS	1/4-20	7/16-14	303 Stainless Steel	0.437	0.261	0.072	0.075	0.085
3334-1/4HWSS	1/4-28	7/16-14	303 Stainless Steel	0.437	0.261	0.072	0.075	0.085
3332-5/16HWSS	5/16-18	1/2-13	303 Stainless Steel	0.484	0.323	0.081	0.080	0.090
3334-5/16HWSS	5/16-24	1/2-13	303 Stainless Steel	0.484	0.323	0.081	0.080	0.090
3332-3/8HWSS	3/8-16	9/16-12	303 Stainless Steel	0.515	0.386	0.091	0.085	0.095
3334-3/8HWSS	3/8-24	9/16-12	303 Stainless Steel	0.515	0.386	0.091	0.085	0.095
3332-7/16HWSS	7/16-14	5/8-11	303 Stainless Steel	0.656	0.447	0.130	0.110	0.115
3334-7/16HWSS	7/16-20	5/8-11	303 Stainless Steel	0.656	0.447	0.130	0.110	0.115
3332-1/2HWSS	1/2-13	3/4-10	303 Stainless Steel	0.656	0.510	0.130	0.110	0.115
3334-1/2HWSS	1/2-20	3/4-10	303 Stainless Steel	0.656	0.510	0.130	0.110	0.115
3332-5/8HWSS	5/8-11	7/8-9	303 Stainless Steel	0.687	0.640	0.130	0.125	0.130
3332-3/4HWSS	3/4-10	1-8	303 Stainless Steel	0.781	0.765	0.130	0.125	0.130



UNC INTERNAL METRIC EXTERNAL SERIES								
PART #	INTERNAL THREAD INCH 2B	EXTERNAL THREAD MM 6G	MATERIAL	L INCH	A INCH	B INCH	C INCH	D INCH
3332-6GHWM	6-32	M6-1.0	C12L14 Carbon Steel	0.256	0.148	0.064	0.062	0.070
3332-8GHWM	8-32	M8-1.25	C12L14 Carbon Steel	0.295	0.177	0.064	0.062	0.075
3332-10GHWM	10-24	M8-1.25	C12L14 Carbon Steel	0.295	0.201	0.064	0.070	0.080
3334-10GHWM	10-32	M8-1.25	C12L14 Carbon Steel	0.295	0.201	0.064	0.070	0.080
3332-1/4HWM	1/4-20	M10-1.5	C12L14 Carbon Steel	0.413	0.261	0.072	0.075	0.085
3332-5/16HWM	5/16-18	M12-1.75	C12L14 Carbon Steel	0.492	0.323	0.081	0.080	0.090
3332-3/8HWM	3/8-16	M16-2.0	C12L14 Carbon Steel	0.669	0.386	0.091	0.085	0.095
3332-1/2HWM	1/2-13	M16-2.0	C12L14 Carbon Steel	0.669	0.510	0.130	0.110	0.115

METRIC INTERNAL UNC EXTERNAL SERIES								
PART #	INTERNAL THREAD MM 6H	EXTERNAL THREAD INCH 2B	MATERIAL	L INCH	A INCH	B INCH	C INCH	D INCH
3320-6.00HWF	M6-1.0	3/8-16	C12L14 Carbon Steel	0.406	0.246	0.064	0.070	0.085
3320-8.00HWF	M8-1.25	1/2-13	C12L14 Carbon Steel	0.484	0.323	0.081	0.080	0.090
3320-10.00HWF	M10-1.5	9/16-12	C12L14 Carbon Steel	0.515	0.403	0.091	0.085	0.095
3321-10.00HWF	M10-1.25	9/16-12	C12L14 Carbon Steel	0.515	0.403	0.091	0.085	0.095
3320-12.00HWF	M12-1.75	3/4-10	C12L14 Carbon Steel	0.656	0.482	0.130	0.110	0.115
3320-14.00HWF	M14-2.0	7/8-9	C12L14 Carbon Steel	0.687	0.640	0.130	0.125	0.130
3320-16.00HWF	M16-2.0	1-8	C12L14 Carbon Steel	0.781	0.640	0.130	0.125	0.130

INSERT STYLE
HEAVY WALL

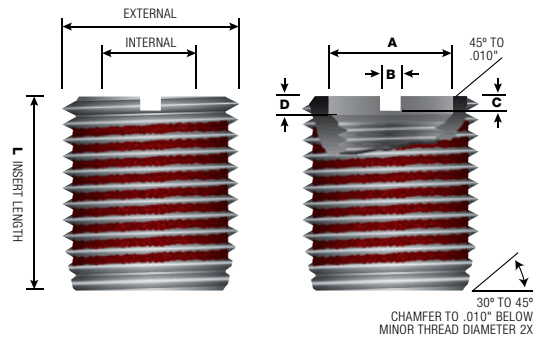

METRIC INTERNAL UNC EXTERNAL SERIES

PART #	INTERNAL THREAD MM 6H	EXTERNAL THREAD INCH 2B	MATERIAL	L MM	A MM	B MM	C MM	D MM
3320-6.00HWSSF	M6-1.0	3/8-16	303 Stainless Steel	0.406	0.246	0.064	0.070	0.085
3320-8.00HWSSF	M8-1.25	1/2-13	303 Stainless Steel	0.484	0.323	0.081	0.080	0.090
3320-10.00HWSSF	M10-1.5	9/16-12	303 Stainless Steel	0.515	0.403	0.091	0.085	0.095
3321-10.00HWSSF	M10-1.25	9/16-12	303 Stainless Steel	0.515	0.403	0.091	0.085	0.095
3320-12.00HWSSF	M12-1.75	3/4-10	303 Stainless Steel	0.656	0.482	0.130	0.110	0.115
3320-14.00HWSSF	M14-2.0	7/8-9	303 Stainless Steel	0.687	0.640	0.130	0.125	0.130
3320-16.00HWSSF	M16-2.0	1-8	303 Stainless Steel	0.781	0.640	0.130	0.125	0.130

INSERT STYLE
EXTRA HEAVY WALL

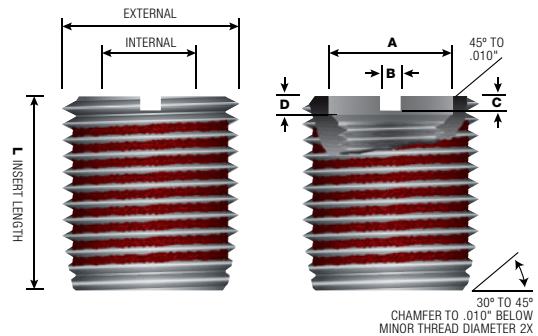

UNC SERIES

PART #	INTERNAL THREAD INCH 2B	EXTERNAL THREAD INCH 2B	MATERIAL	L INCH	A INCH	B INCH	C INCH	D INCH
3332-1/4XHW	1/4-20	1/2-13	C12L14 Carbon Steel	0.484	0.261	0.072	0.075	0.085
3332-5/16XHW	5/16-18	9/16-12	C12L14 Carbon Steel	0.515	0.323	0.081	0.080	0.090
3332-3/8XHW	3/8-16	5/8-11	C12L14 Carbon Steel	0.656	0.385	0.130	0.110	0.115
3332-1/2XHW	1/2-13	7/8-9	C12L14 Carbon Steel	0.687	0.640	0.130	0.125	0.130
3332-5/8XHW	5/8-11	1-8	C12L14 Carbon Steel	0.781	0.760	0.130	0.125	0.130